

# IMPORTANT SAFETY INSTRUCTIONS

**WARNING** – To guard against injury, basic safety precautions should be observed including the following:

## 1. READ AND FOLLOW ALL SAFETY INSTRUCTIONS

- DANGER** – To avoid possible electric shock, special care should be taken since water is employed in the use of aquarium equipment. For each of the following situations, do not attempt to repair yourself; return the appliance to an authorized service facility for service or discard the appliance.
  - If the appliance falls into the water, DON'T reach for it! First unplug it and then retrieve it. If electrical components of the appliance get wet, unplug the appliance completely.
  - Carefully examine the appliance after installation. It should not be plugged in if there is water on the parts not intended to be wet.
  - Do not operate any appliance if it has a damaged cord or plug, or if it is malfunctioning or if it is dropped or damaged in any manner.
  - To avoid the possibility of the appliance plug or receptacle getting wet, position aquarium stand and tank to one side of the wall-mounted receptacle to prevent water from dripping onto the receptacle or plug. As shown in the figure, a "drip loop" should be arranged by the user for each cord connecting an aquarium appliance to the receptacle. The "drip loop" is the part of the cord below the level of the receptacle, or the connector of an extension cord is used, to prevent water travel along the cord and coming in contact with the receptacle. If the plug or the receptacle does get wet, DON'T unplug the cord. Disconnect the fuse to the circuit breaker that supplies power to the appliance. Then unplug and examine for the presence of water in the receptacle.

- Close supervision is necessary when any appliance is used by or near children.
- To avoid injury, do not contact moving parts or hot parts such as heaters, reflectors, lamp bulbs, etc.
- Always unplug an appliance from the outlet when not in use, before putting on or taking off parts, and before cleaning. Never yank the cord to pull plug from the outlet. Grasp the plug and pull to disconnect.
- Do not use an appliance for other than intended use. The use of attachments not recommended or sold by the appliance manufacturer may cause an unsafe condition.
- Do not install or store the appliance where it will be exposed to the weather or to temperatures below freezing.
- Make sure an appliance mounted on a tank is securely installed before operating it.
- Read and observe all the important notices on the appliance.
- If an extension cord is necessary, a cord with a proper rating should be used. A cord rated for less amperes or watts than the appliance rating may overheat. Care should be taken to arrange the cord so that it will not be tripped over or pulled.
- This appliance is recommended for use over a glass aquarium cover or panel. The appliance is intended FOR HOUSEHOLD USE ONLY.

### ONLY FOR POLARIZED ATTACHMENT PLUG APPLIANCES

- If this appliance has a polarized plug (one blade is wider than the other) as a safety feature, this plug will fit in a polarized outlet only one way. If the plug does not fit fully in the outlet, reverse the plug. If it still does not fit, contact a qualified electrician. Never use with an extension cord unless plug can be fully inserted. Do not attempt to defeat this safety feature.

## 13. SAVE THESE INSTRUCTIONS

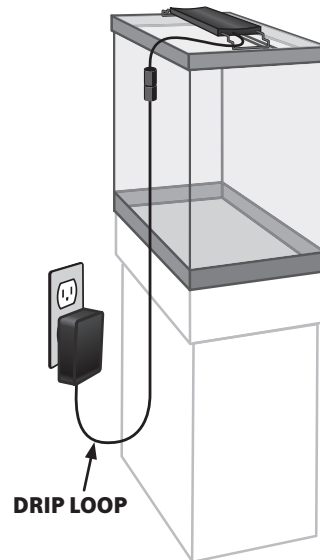

# CONSIGNES DE SÉCURITÉ IMPORTANTES

**AVERTISSEMENT** – Pour protéger contre les blessures, respecter les consignes de sécurité de base, notamment ce qui suit :

## 1. LIRE ET RESPECTER TOUTES LES INSTRUCTIONS DE SÉCURITÉ.

- DANGER** – Pour écarter les risques de décharge électrique, faire preuve de précautions particulières en raison de la présence d'eau dans l'aquarium. Dans chacune des situations ci-dessous, ne pas tenter de réparer soi-même ; renvoyer l'appareil à un centre de réparation agréé ou le mettre au rebut.
  - Si l'appareil tombe dans l'eau, NE PAS y mettre la main ! Débrancher d'abord l'appareil puis le récupérer. Si des composants électriques de l'appareil sont mouillés, le débrancher immédiatement.
  - Examiner l'appareil avec soin après son installation. Ne pas le brancher s'il y a de l'eau sur des pièces non destinées à être mouillées.
  - Ne pas utiliser un appareil s'il a un cordon ou une fiche endommagés, s'il fonctionne mal, s'il est tombé ou s'il a été endommagé d'une quelconque façon.
  - Pour écarter le risque de mouiller la fiche de l'appareil ou la prise de courant, placer le socle et la cuve de l'aquarium sur le côté par rapport à la prise murale, afin d'éviter que l'eau ne goutte sur la prise ou la fiche. Prévoir une « boucle d'égouttement », illustrée ci-dessous, sur chaque cordon qui raccorde un appareil de l'aquarium à la prise de courant. La « boucle d'égouttement » est la portion de cordon en dessous du niveau de la prise, ou du connecteur si un cordon de rallonge est utilisé, pour empêcher l'eau de s'écouler le long du cordon et de venir au contact de la prise. Si la fiche ou la prise sont mouillées, NE PAS débrancher le cordon. Couper l'électricité au niveau du disjoncteur qui alimente l'appareil. Débrancher ensuite le cordon et voir s'il y a de l'eau dans la prise de courant.

- Une supervision étroite est nécessaire lors de l'utilisation de tout appareil électrique par des enfants ou à leur proximité.
- Pour éviter les blessures, ne pas toucher de pièces en mouvement ni de pièces chaudes telles que radiateurs, réflecteurs, ampoules, etc.
- Toujours débrancher un appareil de la prise de courant lorsqu'il n'est pas utilisé, avant de poser ou d'enlever des pièces et avant de le nettoyer. Ne jamais tirer sur le cordon pour sortir la fiche de la prise. Saisir la fiche et tirer pour débrancher.
- Ne pas utiliser un appareil à d'autres fins que celles prévues. L'emploi d'accessoires non recommandés ni vendus par le fabricant de l'appareil peut produire une situation dangereuse.
- Ne pas installer ni entreposer l'appareil dans un endroit exposé aux intempéries ou à des températures inférieures au gel.
- S'assurer qu'un appareil monté sur un aquarium est solidement installé avant de le mettre en marche.
- Lire et respecter toutes les consignes importantes figurant sur l'appareil.
- Si un cordon de rallonge est nécessaire, utiliser un cordon de capacité suffisante. Un cordon prévu pour des intensités (A) ou des puissances (W) inférieures à celles de l'appareil peut surchauffer. Veiller à disposer le cordon de manière à éviter tout risque de trébuchement ou d'arrachement.
- Cet appareil est recommandé pour une utilisation sur un couvercle ou panneau d'aquarium en verre. Ce appareil est destiné à une **UTILISATION DOMESTIQUE SEULEMENT.**

### APPAREILS À FICHE POLARISÉE SEULEMENT

- Si cet appareil comporte une fiche polarisée (une lame plus large que l'autre) par mesure de sécurité, cette fiche ne peut être branchée dans une prise polarisée que dans un sens. Si la fiche ne rentre pas complètement dans la prise, retourner la fiche. Si elle ne rentre toujours pas, contacter un électricien qualifié. Ne jamais utiliser avec un cordon de rallonge si la fiche ne s'enfonce par complètement. Ne pas tenter de contourner ce dispositif de sécurité.

## 13. CONSERVER CES INSTRUCTIONS

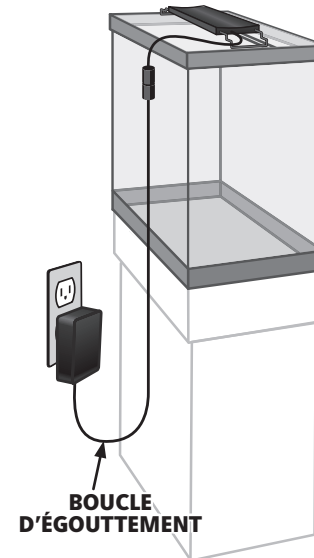

# OptiBright® SMART LED Light



# Seascape SMART LED Light

## OWNER'S MANUAL

Control from anywhere with  
**Aqueon BlueIQ™**

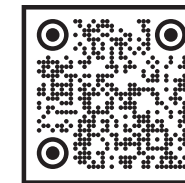

Scan For Free App Download

## FIXTURE INSTALLATION INSTRUCTIONS

- This product is recommended for use over glass-covered aquariums.
- Aqueon® glass covers fit on the inside lip of the aquarium to prevent seepage out of the aquarium.

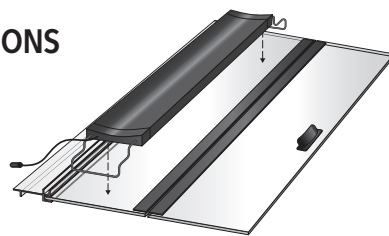

1. Position the fixture over your aquarium by adjusting the legs (Fig 1) to the proper length. The legs should be extended to securely hold the fixture in place. Always center the fixture so that it provides maximum exposure of light to all aquarium inhabitants.
2. Connect the transformer to the jack on the cable on the side of the fixture.
3. Plug the transformer into an acceptable outlet.

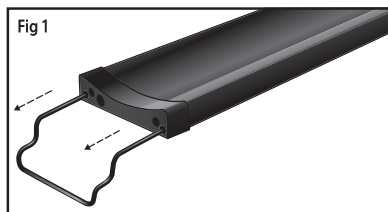

*Be sure to incorporate a "drip loop" to prevent water droplets from running down the cord and into the outlet should any water get onto the cord.*

4. The light fixture will flash when first plugging in. The Wi-Fi indicator light on the side of the fixture will blink when trying to connect to a device. Once connected to either Wi-Fi or Bluetooth, the respective indicator light will remain on to verify it is connected.

## TO PAIR YOUR DEVICE:

*Pairing your fixture using Wi-Fi will give you all light and scheduling features after account set up in the Aqueon BlueIQ™ App.*

1. Download Aqueon BlueIQ™ app.
2. Plug in your fixture.
3. Open the Aqueon BlueIQ™ app.
4. Tap on "Equipment" at the bottom of the app. Your fixture will automatically attempt to pair with your phone if it hasn't been paired with another mobile device yet.
5. Tap Pair on the pop up.

*If fixture does not appear in Equipment screen, make sure your Bluetooth is turned on. If your mobile device has Bluetooth turned on and the fixture does not attempt to pair with your mobile device, complete a factory reset before continuing (See Factory Reset).*

6. After pairing, tap on your fixture listed under "New Equipment" in your app.
7. Choose to connect with either Wi-Fi or Bluetooth from the pop-up.

### Recommended to connect to Wi-Fi:

For full functionality, a Wi-Fi connection is required. If intending to control the device with Bluetooth, some functionality will be limited.

### To switch from a Bluetooth connection to Wi-Fi:

If connected using Bluetooth and want to switch to Wi-Fi for full functionality, go to equipment screen, swipe left on the fixture name and select Forget. Wait for your fixture to appear under New Equipment, then select fixture and choose Connect to Wi-Fi to proceed.

8. If connecting with Wi-Fi, select your Wi-Fi network from the list and enter your credentials when prompted.

**Note:** If you experience connection issues when joining the Wi-Fi network, you may have a weak signal at your device. Please attempt to connect again. If that doesn't work, move your router and fixture so they are closer to each other.

9. After connecting to Wi-Fi, enter a descriptive name for your fixture.
10. Tap your fixture name to start customizing!

## FACTORY RESET

**If your fixture is not able to pair to your mobile device or you want to pair to a different mobile device, you may need to factory reset. Follow these steps to complete the factory reset:**

1. Delete fixture from mobile device Bluetooth settings

### For Apple Users:

- a. Open your settings app
- b. Select Bluetooth
- c. Tap the  icon next to your previously paired device and select "Forget This Device"

### For Android Users:

- a. Open your settings app
- b. Select "Connected Devices"
- c. Tap the  icon for your previously paired device and select "Forget"

2. In the BlueIQ™ app, tap on "Equipment" at the bottom
3. Swipe left on the name of the fixture you are resetting and tap "Forget"
4. Remove the rubber stopper from the reset port on the side of the fixture and insert the end of a paperclip or pen to hit the reset button. Click and hold the reset button for 20 seconds to reset the fixture. The Wi-Fi indicator light will turn off briefly and start blinking when the reset is completed.
5. After factory resetting your device, proceed with pairing your fixture to your mobile device using Wi-Fi or Bluetooth. (*See To Pair Your Device.*)

## IMPORTANT CLEANING & SERVICING PRECAUTIONS

### CLEANING:

It is important to keep this appliance clean. Unplug and remove the unit from the aquarium. Wipe exposed surfaces carefully with a damp cloth to remove any dust or mineral deposits which may collect over time. Make sure all surfaces are dry before reinstalling.

### SERVICING:

In order to assure proper electrical connections and polarity, replacement parts and servicing should be performed only by a qualified electrician.

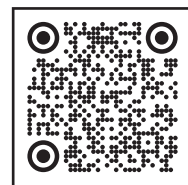

Scan for additional information, help, and suggestions.

### WARNING:

Lightning Mode contains bright, flashing lights that may not be suitable for people with photosensitive epilepsy. Viewer discretion is advised.

## LIMITED WARRANTY

Central Aquatics warrants that this product shall be free from defective electrical components due to defects in materials or workmanship for a period of twelve months from the date of purchase. If a defect is shown, Central Aquatics will, at the sole discretion of Central Aquatics, either repair or replace the product without charge. No cash refunds will be made. This warranty is provided solely to the original consumer purchaser of the product and may not be transferred or assigned. You must retain original proof of purchase to validate this warranty.

This warranty does not apply to damage resulting from accident, misuse, abuse, lack of reasonable care, failure to follow safety and installation instructions, use of the product with non-standard electrical service, or any other defect not resulting from defects in the electrical components of the product or defects in materials or workmanship. This warranty will not be effective unless and until the Central Aquatics product is shown to have been used in accordance with the safety and installation instructions accompanying the product, including the requirement that the product be used over a covered aquarium.

THIS CONSTITUTES THE ENTIRE CENTRAL AQUATICS WARRANTY AND CENTRAL AQUATICS MAKES NO OTHER WARRANTIES, WHETHER EXPRESS OR IMPLIED, WITH RESPECT TO THE PRODUCT. CENTRAL AQUATICS SPECIFICALLY DISCLAIMS ANY AND ALL IMPLIED WARRANTIES, INCLUDING, WITHOUT LIMITATION, WARRANTIES OF MERCHANTABILITY AND FITNESS FOR A PARTICULAR PURPOSE. IF CENTRAL AQUATICS CANNOT LAWFULLY DISCLAIM IMPLIED WARRANTIES UNDER THIS LIMITED WARRANTY, ALL SUCH WARRANTIES, INCLUDING WARRANTIES OF MERCHANTABILITY AND FITNESS FOR A PARTICULAR PURPOSE ARE LIMITED IN DURATION TO THE DURATION OF THIS WARRANTY.

CENTRAL AQUATICS IS NOT RESPONSIBLE FOR DIRECT, SPECIAL, INCIDENTAL OR CONSEQUENTIAL DAMAGES RESULTING FROM ANY BREACH OF WARRANTY OR CONDITION, OR UNDER ANY OTHER LEGAL THEORY. CENTRAL AQUATICS EXPRESSLY DISCLAIMS ALL ALLEGED DAMAGES FOR LOSS OF AQUATIC LIFE, PERSONAL INJURY, AND/OR PROPERTY DAMAGE. Some states and provinces do not allow the exclusion or limitation of incidental or consequential damages or exclusions or limitations on the duration of implied warranties or conditions, so the above limitations or exclusions may not apply to you. This warranty gives you specific legal rights, and you may also have other rights that vary by state or province.

Central Aquatics shall not have any obligations under this warranty unless the owner notifies Central Aquatics in writing of any alleged defect(s) within 30 days of discovery of the defect(s). Any notice to Central Aquatics must be delivered by United States or electronic mail to one of the following addresses:

**U.S. Mail:** Central Aquatics - Aqueon, 5401 West Oakwood Park Drive, Franklin, Wisconsin 53132

**Electronic Mail:** [info@Central-Aquatics.com](mailto:info@Central-Aquatics.com)

Central Aquatics shall be allowed a reasonable period of time to investigate any warranty claim and to perform any testing Central Aquatics deems necessary to determine the cause of the defect. This warranty shall be interpreted under the laws of the state of Wisconsin.

For additional information regarding this limited warranty, please contact us at the addresses above, or call us at 888-255-4527.

## FCC CERTIFICATION

This device complies with Part 15 of the FCC Rules. Operation is subject to the following two conditions: (1) this device may not cause harmful interference, and (2) this device must accept any interference received, including interference that may cause undesired operation.

**WARNING:** Changes or modifications to this unit not expressly approved by the party responsible for compliance could void the user's authority to operate the equipment.

**NOTE:** This equipment has been tested and found to comply with the limits for a Class B digital device, pursuant to Part 15 of the FCC Rules. These limits are designed to provide reasonable protection against harmful interference in a residential installation. This equipment generates uses and can radiate radio frequency energy and, if not installed and used in accordance with the instructions, may cause harmful interference to radio communications.

However, there is no guarantee that interference will not occur in a particular installation. If this equipment does cause harmful interference to radio or television reception, which can be determined by turning the equipment off and on, the user is encouraged to try to correct the interference by one or more of the following measures:

- Reorient or relocate the receiving antenna.
- Increase the separation between the equipment and receiver.
- Connect the equipment into an outlet on a circuit different from that to which the receiver is connected.
- Consult the dealer or an experienced radio/TV technician for help.